

CAST STEEL MOLDS FOR ALUMINIUM



Sow molds are reusable, cast steel molds designed for the casting of aluminium ingot for remelt storage and/or transportation.

Dimensions and design can be customized to customer requirements, including the casting of the customer's logo, and the addition of feet and/or lugs for material handling.

INDUSTRY

- Casthouses
- Remelters

APPLICATIONS

- Cast ingot
- Solid storage/transportation
- Empty trough/furnace

ADVANTAGES

- Reduce annual costs with Pyrotek's competitive pricing
- Local sales contact with local stocking available
- Reduce purchasing costs via vendor consolidation
- Low profile design minimizes shrinkage cavity in the ingot
- Cast steel alloy reduces thermal fatigue (ASTM A-27 grade 65-35 or customer specification)
- Option to include the customer logo in the design
- Both standard and custom mold designs are available

Pricing available FOB plant or nearest port.

SOW MOLDS

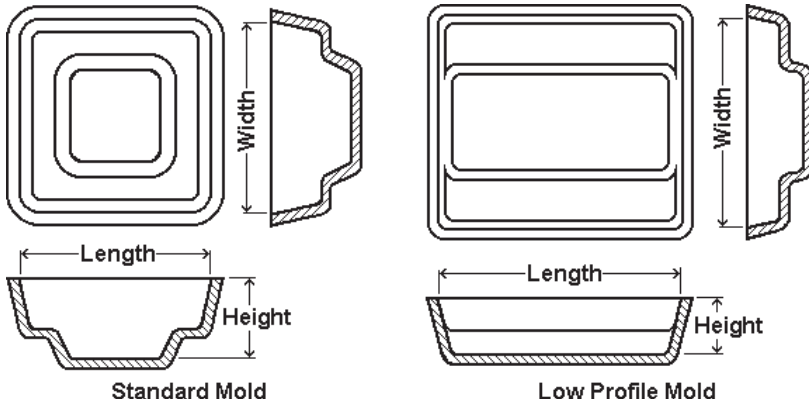

The mold sizes listed in the following table will satisfy most requirements. The low profile design was developed to reduce the shrinkage cavity in the aluminium casting, and is now widely used by most major producers. Custom designs are available for customers with specific needs. Molds may be modified to add customer logo, feet and/or lugs for material handling. Standard designs are available with no tooling charges.

STANDARD PROFILE MOLDS							
ALUMINIUM INGOT SIZE (lb)	APPROXIMATE MOLD WEIGHT (lb)	INSIDE MOLD DIMENSIONS					
		HEIGHT		LENGTH		WIDTH	
1000	1250	14 1/4 in	362.0 mm	34 7/8 in	885.8 mm	34 7/8 in	885.8 mm
1200	1320	16 in	406.4 mm	35 7/8 in	991.2 mm	35 7/8 in	991.2 mm
LOW PROFILE MOLDS							
ALUMINIUM INGOT SIZE (lb)	APPROXIMATE MOLD WEIGHT (lb)	INSIDE MOLD DIMENSIONS					
		HEIGHT		LENGTH		WIDTH	
1200	2200	10 1/8 in	257.2 mm	50 7/8 in	1292.2 mm	43 5/8 in	1108.1 mm
1500	2250	11 5/8 in	295.3 mm	51 5/8 in	1311.3 mm	44 3/8 in	1127.1 mm
1700	2300	12 5/8 in	320.7 mm	52 1/8 in	1324.0 mm	44 7/8 in	1140.0 mm
2000	2360	14 1/8 in	325.8 mm	52 7/8 in	1343.0 mm	45 5/8 in	1159.0 mm

Note: The physical and chemical properties listed represent typical, average values obtained in accordance with accepted test methods and are subject to normal manufacturing variations. They are supplied as a technical service and are subject to change without notice.

REGIONAL HEADQUARTERS

EUROPE/RUSSIA/MIDDLE EAST

Czech Republic (420) 516-527-111
 Germany (49) 02182-81020
 Italy (39) 010-846-8627
 Russia/CIS (7) 495-230-71-63
 Sweden (46) 0534-62000
 Spain (34) 976-222-545
 Switzerland (41) 027-455-8264
 Turkey (90) 212-230-30-33
 United Arab Emirates (971) 04-883-77-00
 United Kingdom (44) 011 908-561155

AFRICA

(27) 035-797-4039

ASIA

(86) 755-26632324

AUSTRALIA

(61) 02 9631-1333

CANADA

(819) 477-0734

INDIA

(91) 2137-668000

JAPAN

(81) 078 265-5590

MEXICO

(52) 1-811-247-8000

NEW ZEALAND

(64) 09 272-2056

SOUTH AMERICA

(55) 11-4786-5233

Product Type: 190

Commodity Code: 03006